

片落管 (R管レデューサー)

SPIRAL JOINT

呼び名 : R-D₁ × D₂

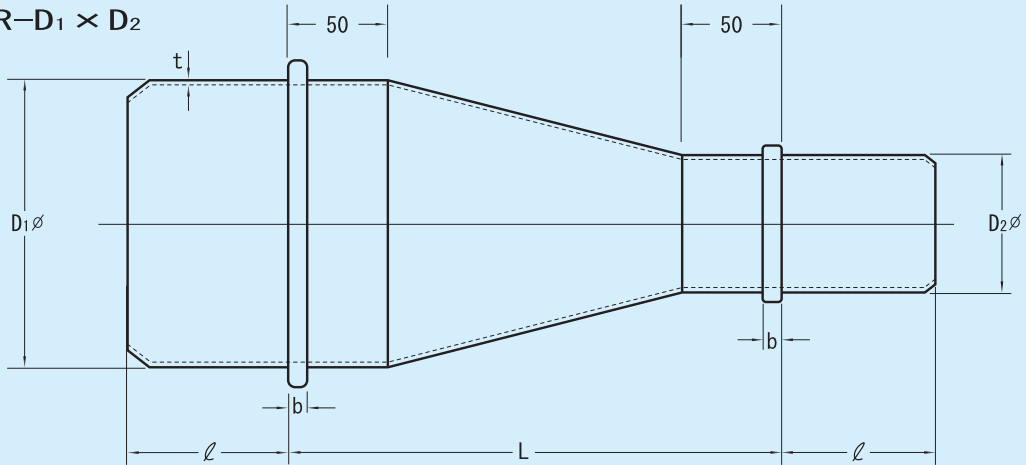

呼び径		t	b	L	ℓ
D ₁	D ₂				
125	100	0.6	8	150	60
150	100	0.6	10	200	80
	125	0.6	10	150	80
175	100	0.6	10	250	80
	125	0.6	10	200	80
200	150	0.6	10	150	80
	100	0.6	10	300	80
	125	0.6	10	250	80
225	150	0.6	10	200	80
	175	0.6	10	150	80
	100	0.6	10	350	80
250	125	0.6	10	300	80
	150	0.6	10	250	80
	175	0.6	10	200	80
	200	0.6	10	150	80
275	100	0.6	10	450	80
	125	0.6	10	400	80
	150	0.6	10	350	80
	175	0.6	10	300	80
	200	0.6	10	250	80
	225	0.6	10	200	80
	250	0.6	10	150	80
	100	0.6	10	500	80
300	125	0.6	10	450	80
	150	0.6	10	400	80
	175	0.6	10	350	80
	200	0.6	10	300	80
	225	0.6	10	250	80
	250	0.6	10	200	80
	275	0.6	10	150	80
	100	0.6	10	550	100
325	125	0.6	10	500	100
	150	0.6	10	450	100
	175	0.6	10	400	100
	200	0.6	10	350	100
	225	0.6	10	300	100
	250	0.6	10	250	100
	275	0.6	10	200	100
	300	0.6	10	150	100
350	100	0.8	10	600	100
	125	0.8	10	550	100
	150	0.8	10	500	100
	175	0.8	10	450	100
	200	0.8	10	400	100

呼び径		t	b	L	ℓ
D ₁	D ₂				
350	225	0.8	10	350	100
	250	0.8	10	300	100
	275	0.8	10	250	100
	300	0.8	10	200	100
	325	0.8	10	150	100
400	175	0.8	10	550	100
	200	0.8	10	500	100
	225	0.8	10	450	100
	250	0.8	10	400	100
	275	0.8	10	350	100
	300	0.8	10	300	100
	325	0.8	10	250	100
	350	0.8	10	200	100
450	375	0.8	10	150	100
	100	0.8	10	700	100
	175	0.8	10	650	100
	200	0.8	10	600	100
	225	0.8	10	550	100
	250	0.8	10	500	100
	275	0.8	10	450	100
	300	0.8	10	400	100
500	325	0.8	10	350	100
	350	0.8	10	300	100
	375	0.8	10	250	100
	400	0.8	10	200	100
	200	0.8	10	700	100
	225	0.8	10	650	100
	250	0.8	10	600	100
	275	0.8	10	550	100
	300	0.8	10	500	100
	325	0.8	10	450	100
550	350	0.8	10	400	100
	375	0.8	10	350	100
	400	0.8	10	300	100
	450	0.8	10	200	100
	200	0.8	10	800	100
	225	0.8	10	750	100
	250	0.8	10	700	100
	275	0.8	10	650	100
	300	0.8	10	600	100
	325	0.8	10	550	100
600	350	0.8	10	500	100
	375	0.8	10	450	100
	400	0.8	10	400	100
	450	0.8	10	300	100
	500	0.8	10	200	100
	300	0.8	10	700	100
	350	0.8	10	600	100
	400	0.8	10	500	100
	450	0.8	10	400	100
	450	0.8	10	400	100

呼び径		t	b	L	ℓ
D ₁	D ₂				
600	500	0.8	10	300	100
	550	0.8	10	200	100
650	300	0.8	10	800	100
	350	0.8	10	700	100
	400	0.8	10	600	100
	450	0.8	10	500	100
	500	0.8	10	400	100
	550	0.8	10	300	100
	600	0.8	10	200	100
700	300	0.8	10	900	100
	350	0.8	10	800	100
	400	0.8	10	700	100
	450	0.8	10	600	100
	500	0.8	10	500	100
	550	0.8	10	400	100
	600	0.8	10	300	100
750	650	0.8	10	200	100
	300	0.8	10	1000	100
	350	0.8	10	900	100
	400	0.8	10	800	100
	450	0.8	10	700	100
	500	0.8	10	600	100
	550	0.8	10	500	100
800	600	0.8	10	400	100
	650	0.8	10	300	100
	700	0.8	10	200	100
	400	1.0	10	900	100
	450	1.0	10	800	100
	500	1.0	10	700	100
	550	1.0	10	600	100
900	600	1.0	10	500	100
	650	1.0	10	400	100
	700	1.0	10	300	100
	750	1.0	10	200	100
	500	1.0	10	900	100
	550	1.0	10	800	100
	600	1.0	10	700	100
1000	650	1.0	10	600	100
	700	1.0	10	500	100
	750	1.0	10	400	100
	800	1.0	10	300	100
	500	1.0	10	1000	100
	550	1.0	10	900	100
	600	1.0	10	800	100

45° Y管 (Y管)

SPIRAL JOINT

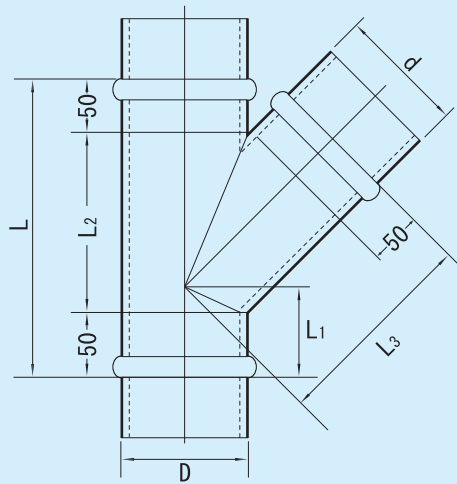

$$L_2 = 1.4d$$

$$L_3 = 0.7D + 0.5d + 50$$

呼び径		各部寸法				
D	d	L	L ₁	L ₂	L ₃	
100	100	240	70	140	170	
125	100	240	60	140	190	
	125	285	75	175	200	
150	100	240	45	140	205	
	125	285	65	175	220	
	150	310	80	210	230	
175	100	240	35	140	225	
	125	285	50	175	235	
	150	310	70	210	250	
200	175	345	90	245	260	
	100	240	20	140	240	
	125	285	40	175	255	
	150	310	55	210	265	
225	175	345	75	245	280	
	200	380	90	280	260	
	100	240	10	140	260	
	125	285	25	175	270	
	150	310	45	210	285	
250	175	345	60	245	295	
	200	380	80	280	310	
	225	415	95	320	320	
	100	240	-5	140	275	
	125	285	15	175	290	
	150	310	30	210	300	
275	175	345	50	245	315	
	200	380	65	280	325	
	225	415	85	320	340	
	250	450	100	355	350	
	100	240	-15	140	290	
	125	285	0	175	305	
	150	310	20	210	320	
300	175	345	35	245	330	
	200	380	55	280	340	
	225	415	70	320	350	
	250	450	90	355	365	
	275	485	105	390	375	
	100	240	-30	140	310	
	125	285	-10	175	325	
	150	310	5	210	335	
300	175	345	25	245	350	
	200	380	40	280	360	
	225	415	60	320	370	
	250	450	75	355	390	
	275	485	95	390	400	

呼び径		各部寸法				
D	d	L	L ₁	L ₂	L ₃	
300	300	520	110	425	410	
325	200	380	30	280	375	
	225	415	45	320	385	
	250	450	65	355	400	
	275	485	80	390	410	
	300	520	100	425	425	
	325	555	115	460	435	
350	200	380	15	280	395	
	225	415	35	320	405	
	250	450	50	355	420	
	275	485	70	390	430	
	300	520	85	425	445	
	325	555	105	460	455	
	350	590	120	495	465	
375	250	450	40	355	435	
	275	485	55	390	450	
	300	520	75	425	460	
	325	555	90	460	475	
	350	590	110	495	485	
	375	625	125	530	500	
	400	660	140	565	515	
400	250	450	25	355	455	
	275	485	45	390	470	
	300	520	60	425	480	
	325	555	80	460	490	
	350	590	95	495	505	
	375	625	115	530	520	
	400	660	135	565	530	
	450	730	140	635	590	
450	300	520	40	425	515	
	350	590	70	595	540	
	400	660	110	565	565	
	450	730	140	635	590	
	500	800	155	705	650	
	550	870	165	775	710	
	600	940	175	845	770	
500	350	590	20	495	610	
	400	660	60	565	635	
	450	730	95	635	660	
	500	800	130	705	685	
	550	870	165	775	710	
	600	940	200	845	735	
	650	1010	235	915	760	
	700	1080	270	985	785	
550	400	660	35	565	670	
	450	730	70	635	695	
	500	800	105	705	720	
	550	870	140	775	745	
	600	940	175	845	770	
	650	1010	210	915	795	
	700	1080	245	985	820	
	750	1150	280	1055	845	
600	450	730	50	635	700	
	500	800	85	705	725	
	550	870	120	775	750	
	600	940	155	845	775	
	650	1010	190	915	800	
	700	1080	225	985	825	
	750	1150	260	1055	850	
	800	1220	295	1125	875	
650	500	800	70	705	730	
	550	870	105	775	755	
	600	940	140	845	780	
	650	1010	175	915	805	
	700	1080	210	985	830	
	750	1150	245	1055	855	
	800	1220	280	1125	880	
	850	1290	315	1195	905	
700	550	870	85	775	780	
	600	940	120	845	805	
	650	1010	155	915	830	
	700	1080	190	985	855	
	750	1150	225	1055	880	
	800	1220	260	1125	905	
	850	1290	295	1195	930	
	900	1360	330	1265	955	
750	600	940	100	845	830	
	650	1010	135	915	855	
	700	1080	170	985	880	
	750	1150	205	1055	905	
	800	1220	240	1125	930	
	850	1290	275	1195	955	
	900	1360	310	1265	980	
	950	1430	345	1335	1005	
800	650	1010	110	915	860	
	700	1080	145	985	885	
	750	1150	180	1055	910	
	800	1220	215	1125	935	
	850	1290	250	1195	960	
	900	1360	285	1265	985	
	950	1430	320	1335	1010	
	1000	1500	355	1405	1035	
850	700	1080	120	985	870	
	750	1150	155	1055	895	
	800	1220	190	1125	920	
	850	1290	225	1195	945	
	900	1360	260	1265	970	
	950	1430	295	1335	995	
	1000	1500	330	1405	1020	
	1050	1570	365	1475	1045	
900	750	1150	130	1055	880	
	800	1220	165	1125	905	
	850	1290	200	1195	930	
	900	1360	235	1265	955	
	950	1430	270	1335	980	
	1000	1500	305	1405	1005	
	1050	1570	340	1475	1030	
	1100	1640	375	1545	1055	
950	800	1220	140	1125	890	
	850	1290	175	1195	915	
	900	1360	210	1265	940	
	950	1430	245	1335	965	
	1000	1500	280	1405	990	
	1050	1570	315	1475	1015	
	1100	1640	350	1545	1040	
	1150	1710	385	1615	1065	
1000	850	1290	150	1195	900	
	900	1360	185	1265	925	
	950	1430	220	1335	950	
	1000	1500	255	1405	975	
	1050	1570	290	1475	1000	
	1100	1640	325	1545	1025	
	1150	1710	360	1615	1050	
	1200	1780	395	1685	1075	

呼び径		各部寸法				
D	d	L	L ₁	L ₂	L ₃	
600	550	870	150	775	745	
600	600	940	175	845	770	
	650	1010	200	915	795	
650	450	730	45	635	730	
	500	800	80	705	755	
	550	870	115	775	780	
	600	940	150	845	805	
	650	1010	190	915	830	
700	500	800	55	705	790	
	550	870	90	775	815	
	600	940	125	845	840	
	650	1010	160	915	865	
	700	1080	195	985	890	
750	550	870	65	775	850	
	600	940	100	845	875	
	650	1010	135	915	900	
	700	1080	170	985	925	
	750	1150	205	1055	950	
800	600	940	75	845	910	
	650	1010	110	915	935	
	700	1080	145	985	960	
	750	1150	180	1055	985	
	800	1220	215	1125	1010	
850	650	1010	85	915	970	
	700	1080	120	985	995	
	750	1150	155	1055	1020	
	800	1220	190	1125	1045	
	850	1290	225	1195	1070	
900	700	1080	95	985	1030	
	750	1150	130	1055	1055	
	800	1220	165	1125	1080	
	850	1290	200	1195	1105	
	900	1360	235	1265	1130	
950	750	1150	105	1055	1090	
	800	1220	140	1125	1115	
	850	1290	175	1195	1140	
	900	1360	210	1265	1165	
	950	1430	245	1335	1190	
1000	800	1220	115	1125	1150	
	850	1290	150	1195	1175	
	900	1360	185	1265	1200	
	950	1430	220	1335	1225	
	1000	1500	255	1405	1250	